

(No Model.)

M. L. WEEKS.
ATTACHMENT FOR LATHES.

No. 458,084.

Patented Aug. 18, 1891.

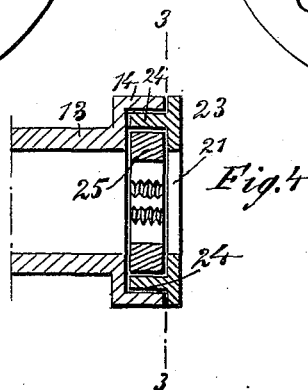
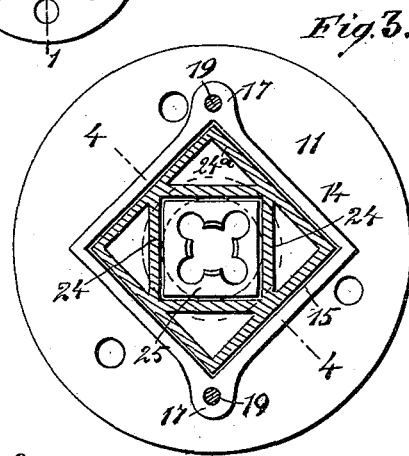
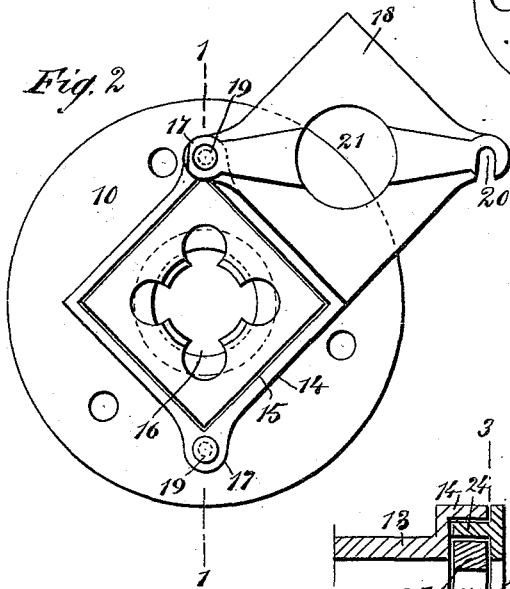
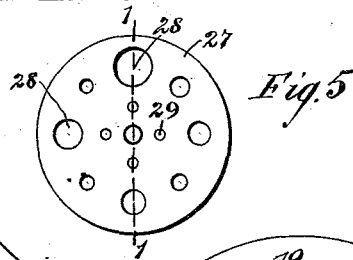
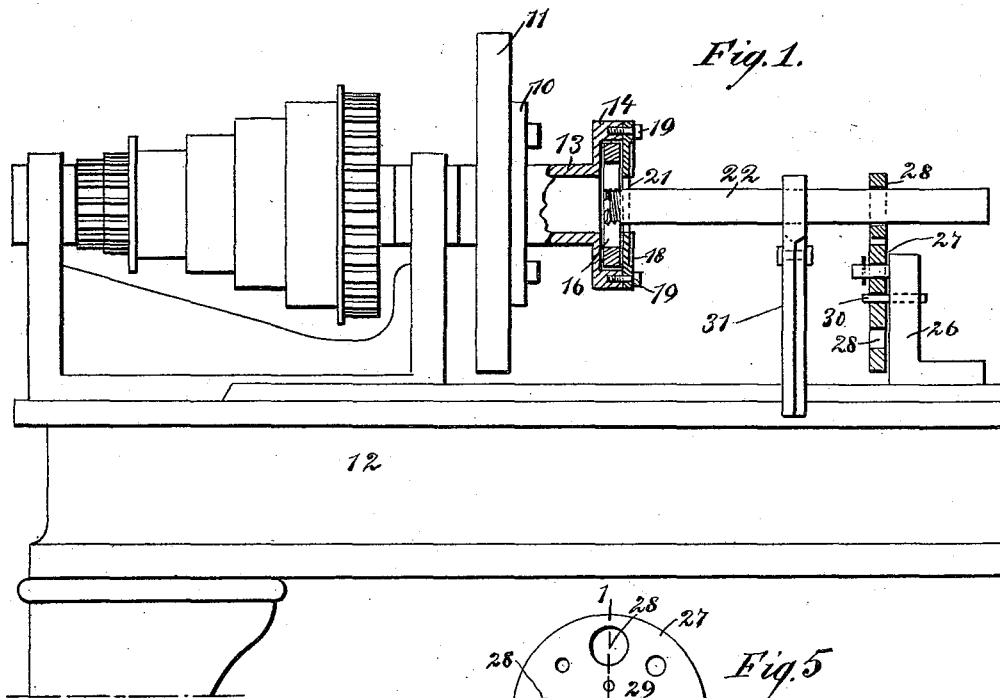

WITNESSES:

Donn Twitchell
C. Sedgwick

INVENTOR:
M. L. Weeks
BY *[Signature]*
ATTORNEYS

UNITED STATES PATENT OFFICE.

MARTIN L. WEEKS, OF YANTIC, CONNECTICUT.

ATTACHMENT FOR LATHES.

SPECIFICATION forming part of Letters Patent No. 458,084, dated August 18, 1891.

Application filed March 19, 1891. Serial No. 385,620. (No model.)

To all whom it may concern:

Be it known that I, MARTIN L. WEEKS, of Yantic, in the county of New London and State of Connecticut, have invented a new and
5 Improved Attachment for Lathes, of which the following is a full, clear, and exact description.

My invention relates to improvements in that class of lathe attachments which are adapted to cut threads upon pipes, bolts, or
10 other articles; and the object of my invention is to produce a convenient and simple device which may be quickly secured to or removed from a lathe, which will hold a die securely in
15 place, which is adapted to hold different sizes of dies, and also to provide adjustable means for holding different-sized pipes and rods in position to be cut by the die.

To this end my invention consists in certain features of construction and combinations of parts, which will be hereinafter described and claimed.

Reference is to be had to the accompanying drawings, forming a part of this specification, in which similar figures of reference indicate
25 corresponding parts in all the views.

Figure 1 is a broken side elevation, partly in section, of a lathe provided with the attachments embodying my invention, the section of the die-holder being taken on the line 1 1
30 in Fig. 2 and the section of the pipe-holder being taken on the line 1 1 in Fig. 5. Fig. 2 is a plan of the die-holder arranged to hold a large-sized die. Fig. 3 is a sectional plan of the die-holder on the line 3 3 in Fig. 4, showing it as adapted to hold a small-sized die. Fig.
35 4 is a broken longitudinal section of the die-holder on the line 4 4 in Fig. 3, and Fig. 5 is a detail plan of the pipe-holding disk.

The die-holder is provided at one end with
40 an annular flange 10, which is adapted to be bolted to the face-plate 11 of an ordinary lathe 12, and projecting from the central portion of the flange is a hollow shank 13, which terminates at one end in a head 14, and the head is
45 chambered out so as to form a square socket 15, which socket is of a size to hold a large-sized die 16. The head is provided on opposite sides with lugs 17, and the die 16 is held
50 in place in the socket of the head by means of a plate 18, which covers the head and which is bolted to the lugs 17 by screws 19, the plate

having one end slotted, as shown at 20, so that it may easily swing over a screw, and having in the center a hole 21, which aligns with the center hole of the die and which is adapted to
55 receive the end of a pipe 22.

When a large-sized die is used, as in Figs. 1 and 2, the plate 18 is made flat on the inner side, so as to fit closely upon the die and so as to permit it to swing on the head, as shown in
60 Fig. 2. For a small-sized die a plate 23 is used, which plate has a center opening 21 for the pipe and is secured to the lugs 17 by means of screws, like the plate 18, already described; but the plate 23 has on the inner side project-
65 ing ribs 24, which are adapted to project into the chamber of the head 14 and which form a rectangular socket adapted to receive a small die 25; and in order that the plate may be held rigidly to the head it is provided around the
70 edge with a flange 24^a, which projects into the chamber 15 of the head 14 and prevents all lateral movement of the plate.

When a small-sized die is to be used, the larger die 16 is removed from the chamber 15,
75 the plate 18 is removed, the small die 25 is placed in the chamber, and the plate 23 is secured to the head 14, so that the ribs 24 will embrace the die, as shown in Fig. 3, and hold the die securely in place.
80

To support the end of the pipe opposite the end which enters the die, the following pipe-holder is used: A base 26 is secured upon the bed of the lathe, said base extending high
85 enough above the bed to conveniently support a disk 27, which is pivoted thereon near the upper end of the base, and the disk 27 is large enough so that its upper portion will align with the center of the lathe. The disk
90 27 is provided around its outer portion with different sizes of holes 28, which holes are arranged to align with the lathe-centers and which are adapted to receive and support different sizes of pipes. The disk is also provided
95 with a series of holes 29, which are arranged nearer its center and which align with a hole in the base 26, and to hold the disk in a fixed position a pin 30 is inserted through one of the holes 29 and the hole in the base,
100 as shown in Fig. 1.

When the attachments are to be used in a lathe, the die-holder is secured to the face-

plate, as described, the pipe-holder is mounted upon the lathe-bed, and a pipe is thrust through one of the holes in the pipe-holder and into the opening of the die, and to prevent the pipe from turning a pair of pipe-tongs 31 are clamped upon it and allowed to rest against the bed of the lathe, as shown in Fig. 1, and when the lathe is started the die will cut a thread on the pipe, and will also cause the pipe to feed itself.

The invention is especially intended for cutting threads on small pipes and rods and for doing miscellaneous work of this character. The dies usually come in standard sizes and the die-holder is adapted to hold these sizes of dies. It is obvious, however, that the die-holder may be made to hold dies of any kind or of more than two sizes, if desired.

Having thus described my invention, I claim as new and desire to secure by Letters Patent—

1. In an attachment for lathes, a die-holder comprising a flanged pipe having a chambered head at the end opposite the flange and a perforated cover for the chamber, said cover having a socket on its inner side, substantially as described.

2. In an attachment for lathes, a die-holder

comprising a flanged pipe having a chambered head at the end opposite the flange and a perforated plate or cover for the chamber, said cover having an inner marginal flange and a central socket, substantially as described. 30

3. In an attachment for lathes, a pipe-holder comprising a base adapted to rest upon a lathe-bed, a perforated disk pivoted on the base, and means for rigidly securing the disk to the base, substantially as described. 35

4. In an attachment for lathes, a pipe-holder comprising a base adapted to fit a lathe-bed and having a hole in its upper portion, and a disk pivoted on the base and provided near the edge with holes of different sizes and near the center with holes adapted to align with the hole in the base, substantially as described. 45

5. An attachment for lathes, comprising a flanged pipe adapted to be secured to the face-plate of a lathe and provided with a chambered head, a perforated socketed plate to cover the chamber of the head, and an adjustable pipe-holder adapted to be placed opposite the die-holder, substantially as described. 50

MARTIN L. WEEKS.

Witnesses:

PAUL SMITH,

CHARLES N. CONGDON.